

# 600V Half Bridge Driver

## PRODUCT SUMMARY

- $V_{\text{OFFSET}}$  600 V max.
- $I_{\text{O+/- (typ.)}}$  290 mA/600 mA
- $V_{\text{OUT}}$  13.5 V - 22 V
- $t_{\text{on/off (typ.)}}$  200 ns/200 ns

## GENERAL DESCRIPTION

The SiLM2207 is a high voltage, high speed power MOSFET and IGBT drivers. Proprietary HVIC and latch immune CMOS technologies enable ruggedized monolithic construction. The logic input is compatible with standard CMOS or LSTTL output, down to 3.3 V logic. The output drivers feature a high pulse current buffer stage designed for minimum driver cross conduction. The floating channel can be used to drive an N-channel power MOSFET or IGBT in the high-side configuration which operates up to 600 V.

## FEATURES

- Floating channel designed for bootstrap operation
- Fully operational to 600 V
- Tolerant to negative transient voltage, dV/dt immune
- Gate drive supply range from 13.5 V to 22 V
- Integrate boost diode
- UVLO for both high-side and low-side drivers
- 3.3 V, 5 V, and 15 V logic compatible
- Cross-conduction prevention logic
- Maximum negative input voltage handling on input -5V
- Matched propagation delay for both channels
- Outputs in phase with inputs
- RoHS compliant
- SOP8 package

## TYPICAL APPLICATION CIRCUIT

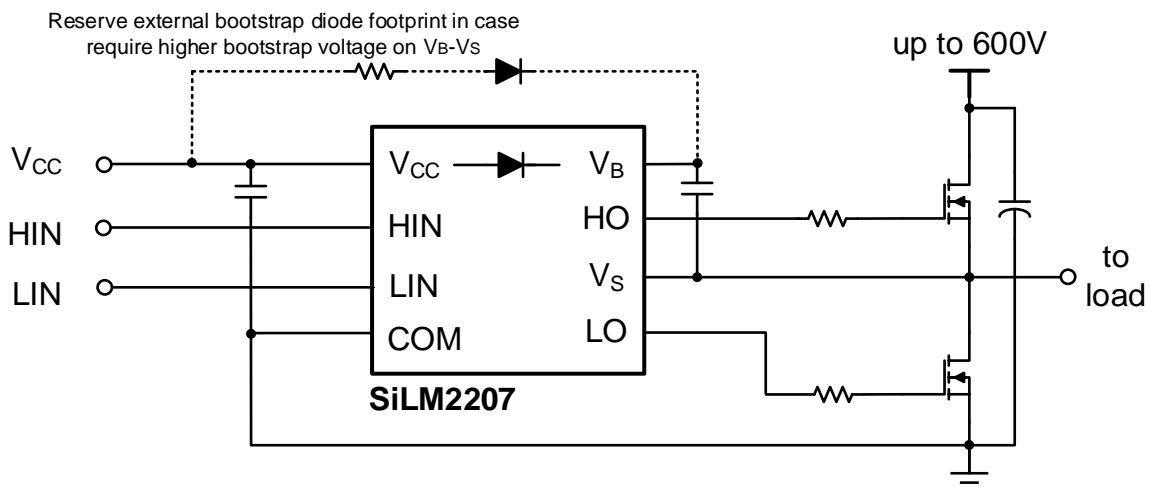
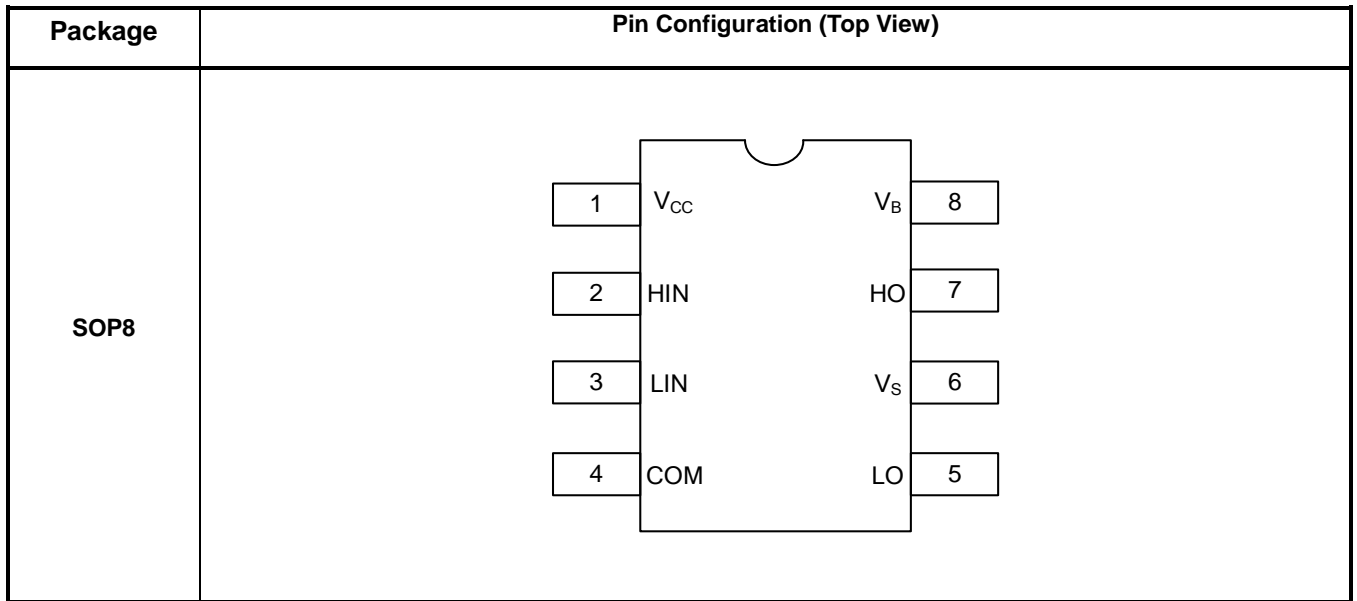

Figure 1. Typical Application Circuit

---

**Table of Contents**

Product Summary .....	1
General Description .....	1
Features .....	1
Typical Application Circuit.....	1
Pin Configuration .....	3
Pin Description.....	3
Ordering Information.....	3
Functional Block Diagram.....	4
Absolute Maximum Ratings .....	5
Recommended Operation Conditions .....	5
Dynamic Electrical Characteristics .....	6
Static Electrical Characteristics .....	6
Package Case Outlines .....	8
Revision History .....	9

**PIN CONFIGURATION**

**PIN DESCRIPTION**

Pin No.	Pin Name	Description
1	V <sub>cc</sub>	Low-side and logic fixed supply
2	HIN	Logic input for high-side gate driver output (HO), in phase
3	LIN	Logic input for low-side gate driver output (LO), in phase
4	COM	Low-side return
5	LO	Low-side gate drive output
6	V <sub>s</sub>	High-side floating supply return
7	HO	High-side gate drive output
8	V <sub>B</sub>	High-side floating supply

**ORDERING INFORMATION**

Industrial Range: -40°C to +125°C

Order Part No.	Package	QTY
SiLM2207CA-DG	SOP8, Pb-Free	2500/Reel

**FUNCTIONAL BLOCK DIAGRAM**

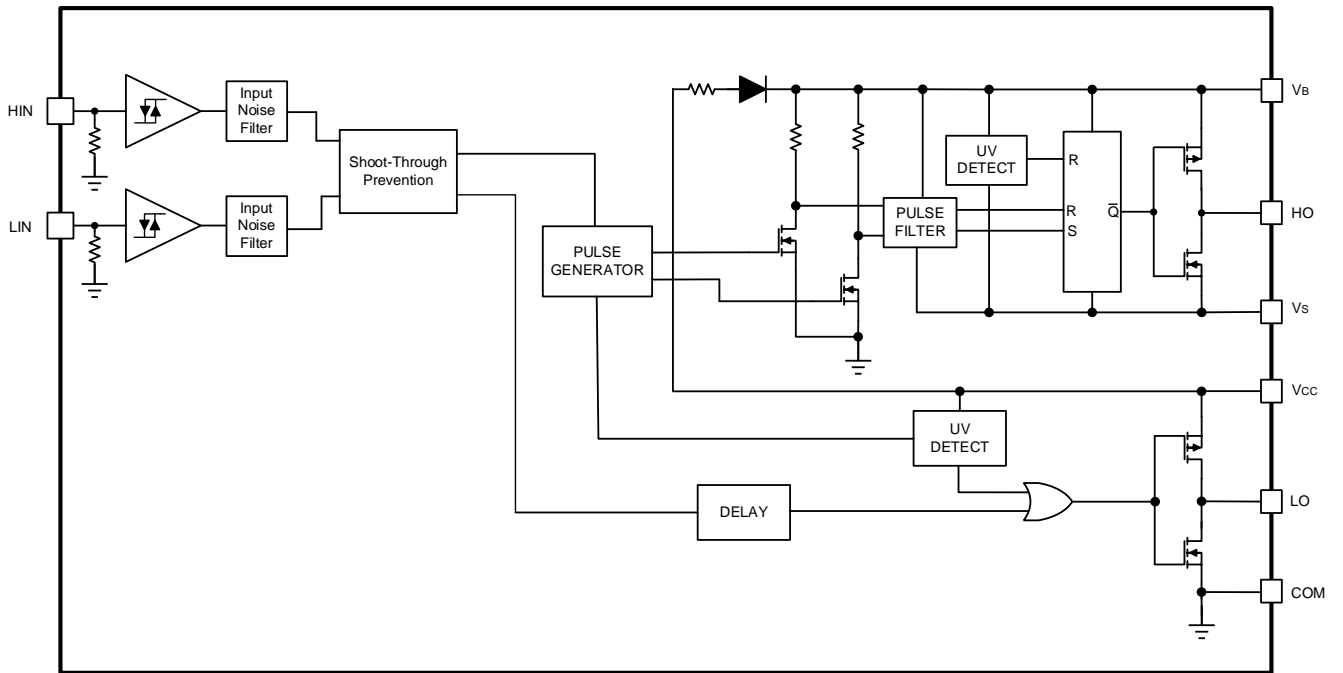

Figure 2. Function Block Diagram

**ABSOLUTE MAXIMUM RATINGS**

Symbol	Definition	Min.	Max.	Units
V <sub>B</sub>	High-side floating absolute voltage	- 0.3	625	V
V <sub>S</sub>	High-side floating supply offset voltage	V <sub>B</sub> - 25	V <sub>B</sub> + 0.3	
V <sub>HO</sub>	High-side floating output voltage	V <sub>S</sub> - 0.3	V <sub>B</sub> + 0.3	
V <sub>CC</sub>	Low-side and logic fixed supply voltage	- 0.3	25	
V <sub>LO</sub>	Low-side output voltage	- 0.3	V <sub>CC</sub> + 0.3	
V <sub>IN</sub>	Logic input voltage (HIN & LIN)	- 6	V <sub>CC</sub> + 0.3	
dV <sub>S</sub> /dt	Allowable offset supply voltage transient	---	50	V/ns
P <sub>D</sub>	Package power dissipation @ T <sub>A</sub> ≤ +25°C	---	0.625	W
θ <sub>JA</sub>	Thermal resistance, junction to ambient	---	200	°C/W
T <sub>J</sub>	Junction temperature	---	150	°C
T <sub>S</sub>	Storage temperature	- 55	150	
T <sub>L</sub>	Lead temperature (soldering, 10 seconds)	---	300	

**Note:** Absolute maximum ratings indicate sustained limits beyond which damage to the device may occur. All voltage parameters are absolute voltages referenced to COM. The thermal resistance and power dissipation ratings are measured under board mounted and still air conditions.

**RECOMMENDED OPERATION CONDITIONS**

Symbol	Definition	Min.	Max.	Units
V <sub>B</sub>	High-side floating absolute voltage	V <sub>S</sub> + 12.5	V <sub>S</sub> + 22	V
V <sub>S</sub>	High-side floating supply offset voltage	- 9	600	
V <sub>HO</sub>	High-side floating output voltage	V <sub>S</sub>	V <sub>B</sub>	
V <sub>CC</sub>	Low-side and logic fixed supply voltage	13.5	22	
V <sub>LO</sub>	Low-side output voltage	0	V <sub>CC</sub>	
V <sub>IN</sub>	Logic input voltage (HIN & LIN)	- 5	V <sub>CC</sub>	
T <sub>A</sub>	Ambient temperature	- 40	125	°C

**Note:** The input/output logic timing diagram is shown in Figure 3. For proper operation the device should be used within the recommended conditions. The V<sub>S</sub> offset rating is tested with all supplies biased at a 15 V differential.

## DYNAMIC ELECTRICAL CHARACTERISTICS

$V_{BIAS}$  ( $V_{CC}$ ,  $V_{BS}$ ) = 15 V,  $C_L$  = 1000 pF and  $T_A$  = 25°C unless otherwise specified.

Symbol	Parameter	Condition	Min.	Typ.	Max.	Unit
$t_{on}$	Turn-on propagation delay	$V_S = 0$ V	---	200	260	ns
$t_{off}$	Turn-off propagation delay	$V_S = 0$ V	---	200	260	
$t_r$	Turn-on rise time		---	70	120	
$t_f$	Turn-off fall time		---	25	60	
MT	Delay matching, HS & LS turn-on/off		---	---	35	

## STATIC ELECTRICAL CHARACTERISTICS

$V_{BIAS}$  ( $V_{CC}$ ,  $V_{BS}$ ) = 15 V and  $T_A$  = 25°C unless otherwise specified. The  $V_{IN}$ ,  $V_{TH}$ , and  $I_{IN}$  parameters are referenced to COM and are applicable to all logic input leads: HIN and LIN. The  $V_O$  and  $I_O$  parameters are referenced to COM and are applicable to the respective output leads: HO or LO.

Symbol	Parameter	Condition	Min.	Typ.	Max.	Unit
$V_{IH}$	Logic "1" input voltage threshold		1.6	2.0	2.4	V
$V_{IL}$	Logic "0" input voltage threshold		0.8	1.1	1.5	
$V_{OH}$	High level output voltage, $V_{BIAS} - V_O$	$I_O = 2$ mA	---	0.05	0.2	
$V_{OL}$	Low level output voltage, $V_O$		---	0.02	0.1	
$I_{LK}$	Offset supply leakage current	$V_B = V_S = 600$ V	---	---	50	$\mu$ A
$I_{QBS}$	Quiescent $V_{BS}$ supply current	$V_{IN} = 0$ V	---	60	80	
$I_{QCC}$	Quiescent $V_{CC}$ supply current		---	180	300	
$I_{IN+}$	Logic "1" input bias current	$V_{IN} = 5$ V	---	8	20	
$I_{IN-}$	Logic "0" input bias current	$V_{IN} = 0$ V	---	---	5	
$V_{CCUV+}$	$V_{CC}$ supply undervoltage positive going threshold		11.5	12.5	13.5	V
$V_{CCUV-}$	$V_{CC}$ supply undervoltage negative going threshold		10.5	11.5	12.5	
$V_{BSUV+}$	$V_{BS}$ supply undervoltage positive going threshold		10	11	12	
$V_{BSUV-}$	$V_{BS}$ supply undervoltage negative going threshold		9	10	11	

Symbol	Parameter	Condition	Min.	Typ.	Max.	Unit
$I_{O+}$	Output high short circuit pulsed current <sup>1</sup>	$V_O = 0\text{ V}$ , $V_{IN} = \text{Logic "1"}$ , $PW \leq 10\ \mu\text{s}$	130	290	---	mA
$I_{O-}$	Output low short circuit pulsed current <sup>1</sup>	$V_O = 15\text{ V}$ , $V_{IN} = \text{Logic "0"}$ , $PW \leq 10\ \mu\text{s}$	270	600	---	
$V_{F\_BSD}$	Forward voltage drop from VCC to VB	$I_F = 1\text{ mA}$	---	1.9	2.8	V
$R_{BSD}$	Bootstrap diode on resistor		---	350	---	$\Omega$

1) Bench characterization.

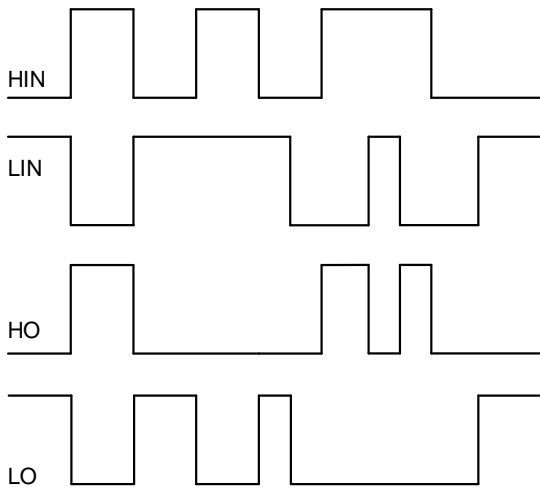

Figure 3. Input/Output Timing Diagram

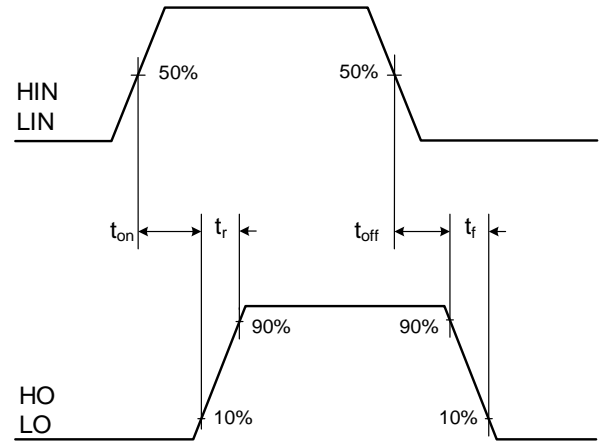

Figure 4. Switching Time Waveform

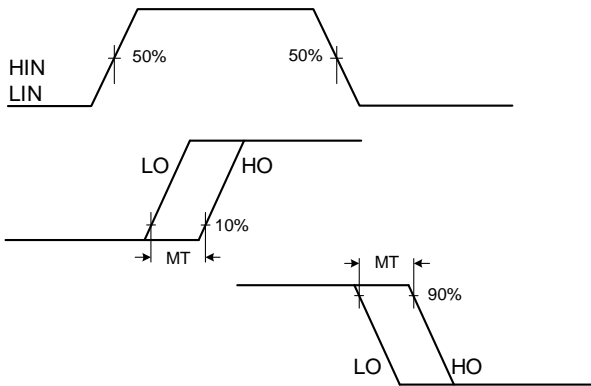

Figure 5. Delay Matching Waveform

**PACKAGE CASE OUTLINES**

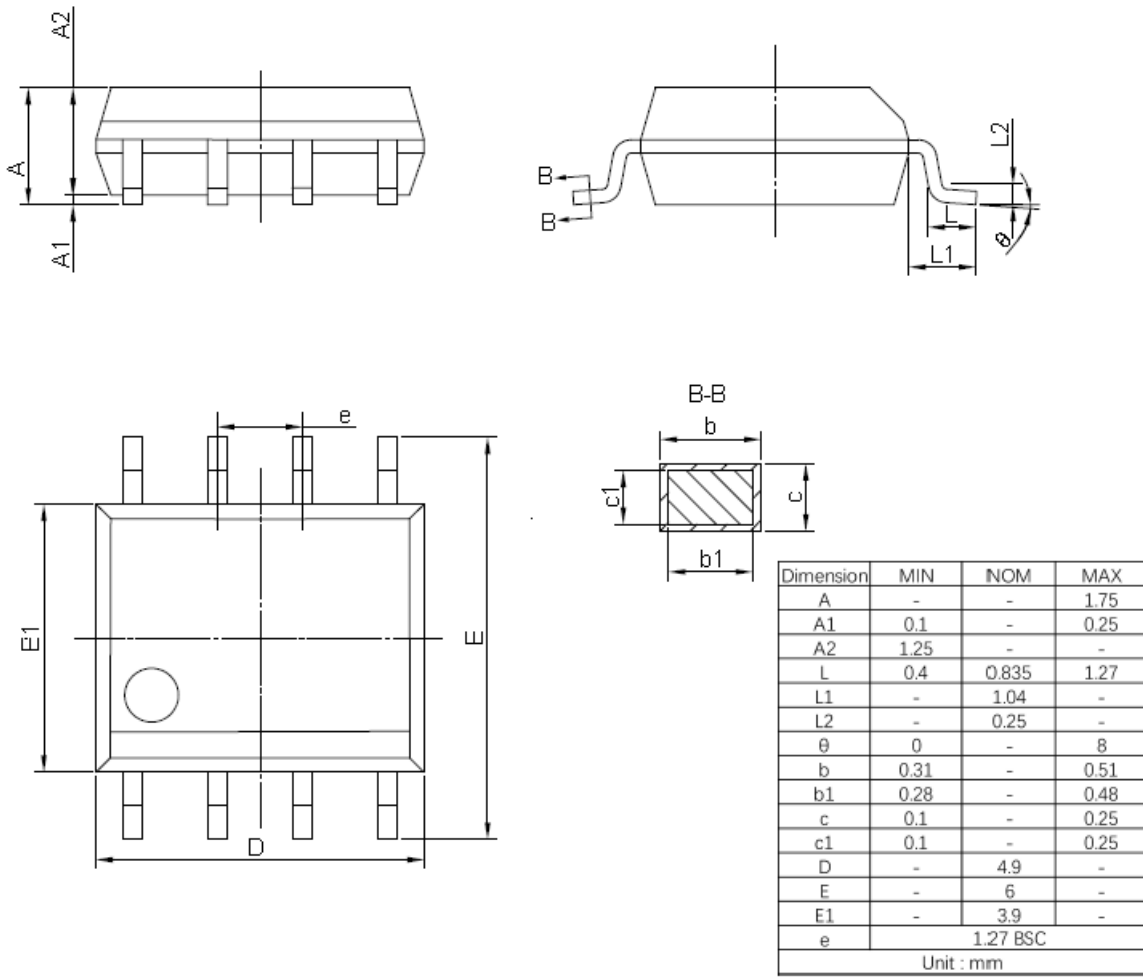

Figure 6. SOP8 Outline Dimensions

---

**REVISION HISTORY**

Note: page numbers for previous revisions may differ from page numbers in current version

<b>Page or Item</b>	<b>Subjects (major changes since previous revision)</b>
<b>Rev 1.0 datasheet, 2025-11-28</b>	
Whole document	Initial datasheet release