

200V Half-Bridge Driver

PRODUCT SUMMARY

- V_{OFFSET} 200 V max.
- $I_{\text{O+/- (typ)}}$ 290 mA/600 mA
- V_{OUT} 10 V - 20 V
- $t_{\text{on/off (typ.)}}$ 680 ns/150 ns
- **Deadtime (typ.)** 520 ns

GENERAL DESCRIPTION

The SiLM2023 is a high voltage, high speed power MOSFET and IGBT drivers with dependent high- and low-side referenced output channels. Proprietary HVIC and latch immune CMOS technologies enable ruggedized monolithic construction. The logic input is compatible with standard CMOS or LSTTL output, down to 3.3 V logic. The output drivers feature a high pulse current buffer stage designed for minimum driver cross conduction. The floating channel can be used to drive an N-channel power MOSFET or IGBT in the high-side configuration which operates up to 200 V.

FEATURES

- Floating channel designed for bootstrap operation
- Fully operational to +200 V
- Tolerant to negative transient voltage, dV/dt immune
- Gate drive supply range from 10 V to 20 V
- Undervoltage lockout
- 3.3 V, 5 V, and 15 V logic compatible
- Cross-conduction prevention logic
- Matched propagation delay for both channels
- Internal set deadtime
- High-side output in phase with $\overline{\text{HIN}}$ input
- Low-side output out of phase with $\overline{\text{LIN}}$ input
- RoHS compliant
- SOP8 package

TYPICAL APPLICATION CIRCUIT

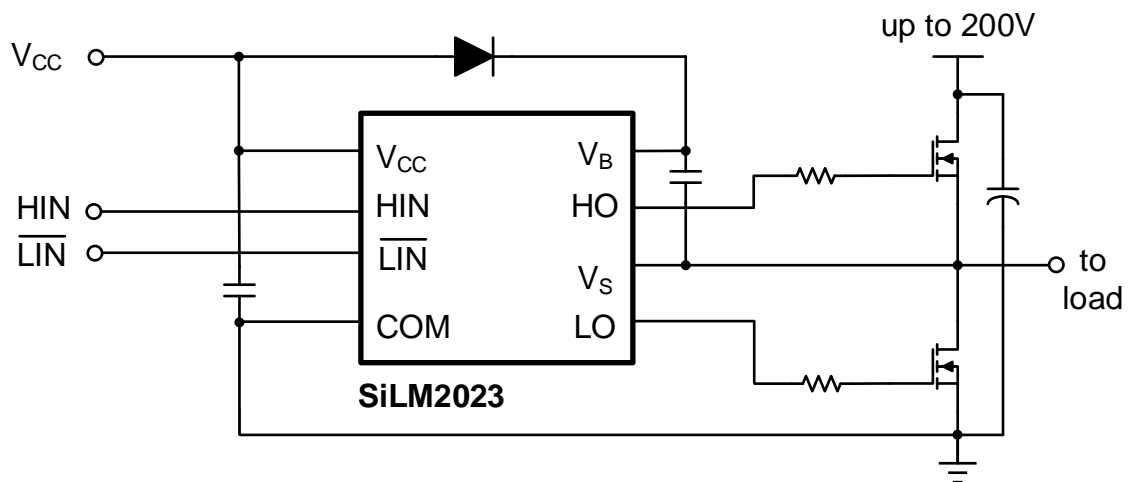
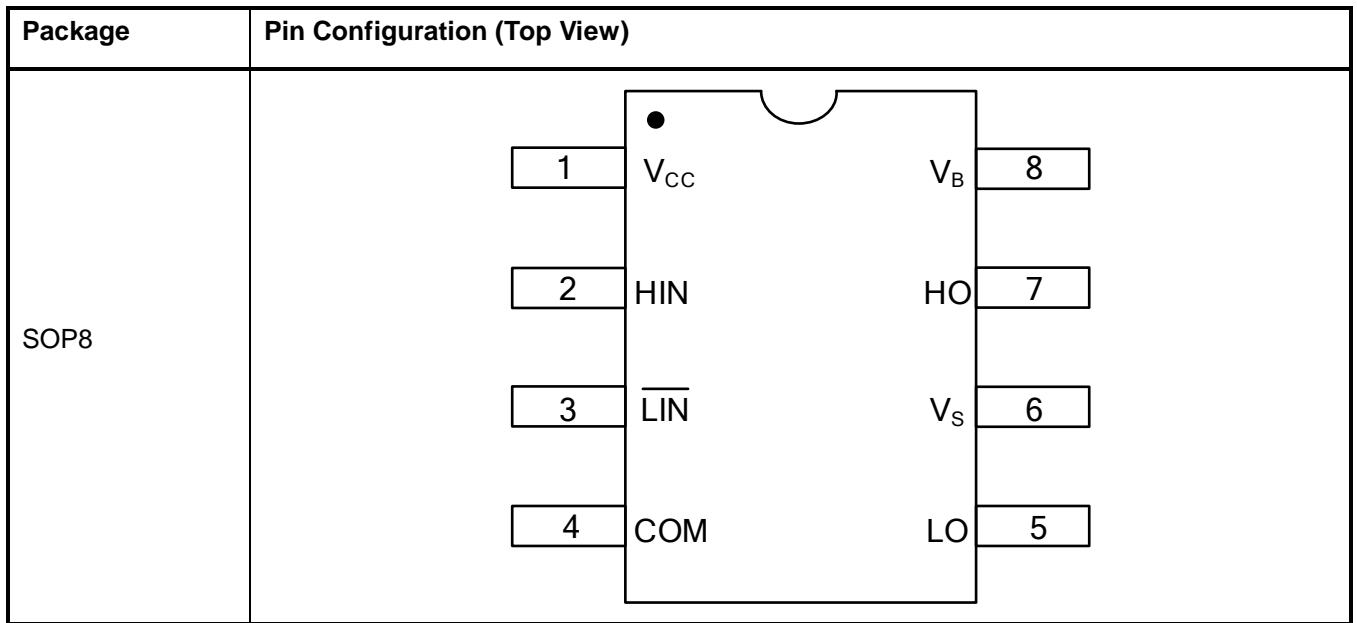

Figure 1. Typical Application Circuit

Table of Contents

Product Summary	1
General Description	1
Features	1
Pin Configuration	3
Pin Description	3
Ordering Information	3
Functional Block Diagram	4
Absolute Maximum Ratings	5
Recommended Operation Conditions	5
Dynamic Electrical Characteristics	6
Static Electrical Characteristics	6
Package Case Outlines	8
Revision History	9

PIN CONFIGURATION

PIN DESCRIPTION

No.	Pin	Description
1	V _{CC}	Low-side and logic fixed supply
2	HIN	Logic input for high-side gate driver output (HO), in phase
3	$\overline{\text{LIN}}$	Logic input for low-side gate driver output (LO), out of phase
4	COM	Low-side return
5	LO	Low-side gate drive output
6	V _S	High-side floating supply return
7	HO	High-side gate drive output
8	V _B	High-side floating supply

ORDERING INFORMATION

Industrial Range: -40°C to +125°C

Order Part No.	Package	QTY
SiLM2023CA-DG	SOP8, Pb-Free	2500/Reel

FUNCTIONAL BLOCK DIAGRAM

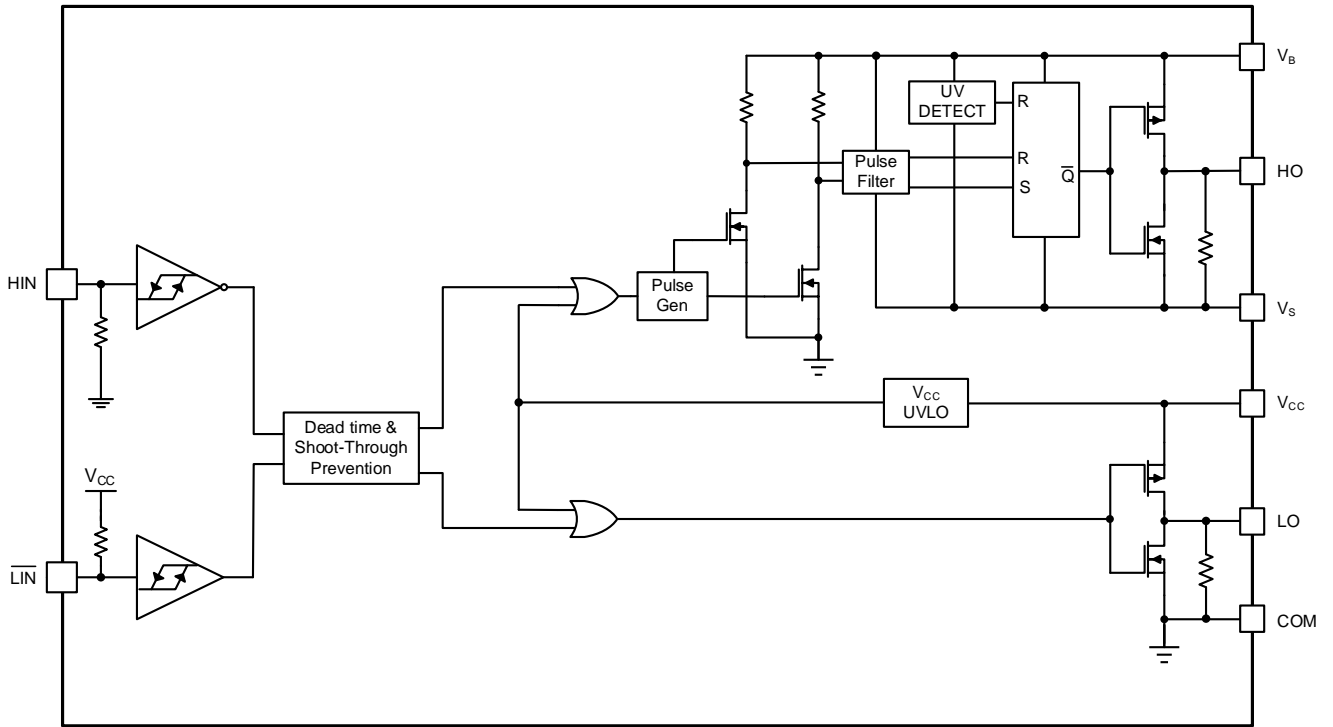

Figure 2. Function Block Diagram

ABSOLUTE MAXIMUM RATINGS

Symbol	Definition	Min.	Max.	Units
V_B	High-side floating absolute voltage	-0.3	225	V
V_S	High-side floating supply offset voltage	$V_B - 25$	$V_B + 0.3$	
V_{HO}	High-side floating output voltage	$V_S - 0.3$	$V_B + 0.3$	
V_{CC}	Low-side and logic fixed supply voltage	-0.3	25	
V_{LO}	Low-side output voltage	-0.3	$V_{CC} + 0.3$	
V_{IN}	Logic input voltage (HIN & \overline{LIN})	-0.3	$V_{CC} + 0.3$	
dV_S/dt	Allowable offset supply voltage transient	---	50	V/ns
P_D	Package power dissipation @ $T_A \leq +25^\circ\text{C}$	---	0.625	W
θ_{JA}	Thermal resistance, junction to ambient	---	200	$^\circ\text{C}/\text{W}$
T_J	Junction temperature	---	150	$^\circ\text{C}$
T_S	Storage temperature	-55	150	
T_L	Lead temperature (soldering, 10 seconds)	---	300	

Note: Absolute maximum ratings indicate sustained limits beyond which damage to the device may occur. All voltage parameters are absolute voltages referenced to COM. The thermal resistance and power dissipation ratings are measured under board mounted and still air conditions.

RECOMMENDED OPERATION CONDITIONS

Symbol	Definition	Min.	Max.	Units
V_B	High-side floating absolute voltage	$V_S + 10$	$V_S + 20$	V
V_S	High-side floating supply offset voltage	-6	200	
V_{HO}	High-side floating output voltage	V_S	V_B	
V_{CC}	Low-side and logic fixed supply voltage	10	20	
V_{LO}	Low-side output voltage	0	V_{CC}	
V_{IN}	Logic input voltage (HIN & \overline{LIN})	0	V_{CC}	
T_A	Ambient temperature	-40	125	$^\circ\text{C}$

Note: The input/output logic timing diagram is shown in Figure 3. For proper operation the device should be used within the recommended conditions. The V_S offset rating is tested with all supplies biased at a 15 V differential.

DYNAMIC ELECTRICAL CHARACTERISTICS

V_{BIAS} (V_{CC} , V_{BS}) = 15 V, C_L = 1000 pF and T_A = 25°C unless otherwise specified.

Symbol	Parameter	Condition	Min.	Typ.	Max.	Unit
t_{on}	Turn-on propagation delay	$V_S = 0$ V	---	680	820	ns
t_{off}	Turn-off propagation delay	$V_S = 0$ V	---	150	260	
t_r	Turn-on rise time		---	70	170	
t_f	Turn-off fall time		---	35	90	
DT	Deadtime, LS turn-off to HS turn-on & HS turn-on to LS turn-off		400	520	750	
MT	Delay matching, HS & LS turn-on/off		---	60	---	

STATIC ELECTRICAL CHARACTERISTICS

V_{BIAS} (V_{CC} , V_{BS}) = 15 V and T_A = 25°C unless otherwise specified. The V_{IN} , V_{TH} , and I_{IN} parameters are referenced to COM and are applicable to all logic input leads: HIN and \overline{LIN} . The V_O and I_O parameters are referenced to COM and are applicable to the respective output leads: HO or LO.

Symbol	Parameter	Condition	Min.	Typ.	Max.	Unit
V_{IH}	Logic "1" (HIN) & Logic "0" (\overline{LIN}) input voltage		2.5	---	---	V
V_{IL}	Logic "0" (HIN) & Logic "1" (\overline{LIN}) input voltage		---	---	0.8	
V_{OH}	High level output voltage, $V_{BIAS} - V_O$	$I_O = 2$ mA	---	0.05	0.2	
V_{OL}	Low level output voltage, V_O		---	0.02	0.1	
I_{LK}	Offset supply leakage current	$V_B = V_S = 200$ V	---	---	10	μ A
I_{QBS}	Quiescent V_{BS} supply current	$V_{IN} = 0$ V	---	60	90	
I_{QCC}	Quiescent V_{CC} supply current		---	250	410	
I_{IN+}	HIN logic "1" input bias current	HIN = 5 V,	---	8	15	
	\overline{LIN} logic "1" input bias current	$\overline{LIN} = 0$ V	---	10	15	
I_{IN-}	HIN logic "0" input bias current	HIN = 0 V,	---	---	1	
	\overline{LIN} logic "0" input bias current	$\overline{LIN} = 5$ V	---	6	15	
V_{CCUV+} V_{BSUV+}	V_{CC} and V_{BS} supply undervoltage positive going threshold		8	8.9	9.8	V
V_{CCUV-} V_{BSUV-}	V_{CC} and V_{BS} supply undervoltage negative going threshold		7.4	8.2	9	

Symbol	Parameter	Condition	Min.	Typ.	Max.	Unit
I_{O+}	Output high short circuit pulsed current ¹	$V_O = 0\text{ V}, V_{IN} = V_{IH}$ $PW \leq 10\ \mu\text{s}$	130	290		mA
I_{O-}	Output low short circuit pulsed current ¹	$V_O = 15\text{ V}, V_{IN} = V_{IL}$ $PW \leq 10\ \mu\text{s}$	270	600		

1) Values are verified by characterization on bench.

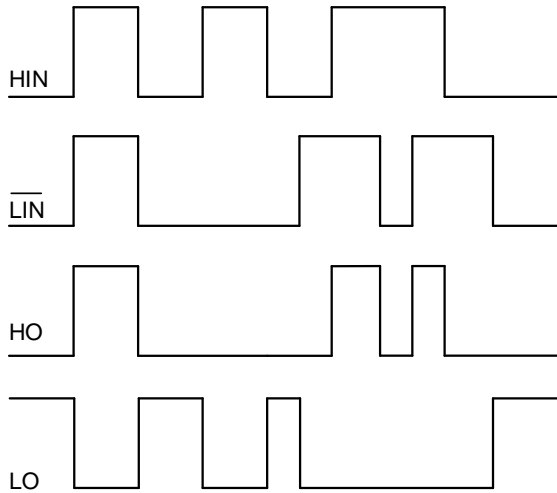

Figure 3. Input/Output Timing Diagram

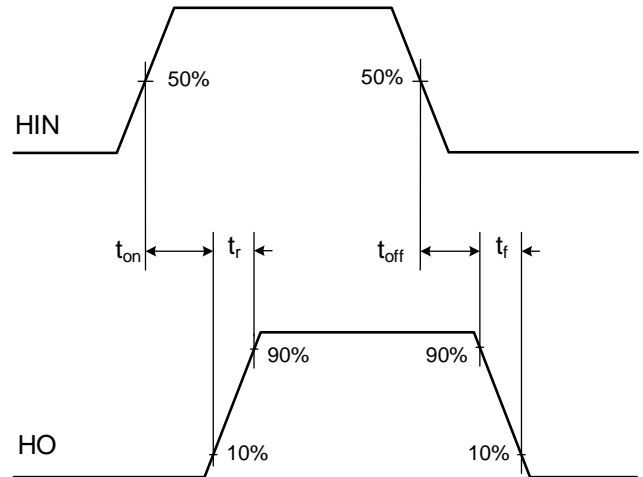

Figure 4. High Side Switching Time Waveform

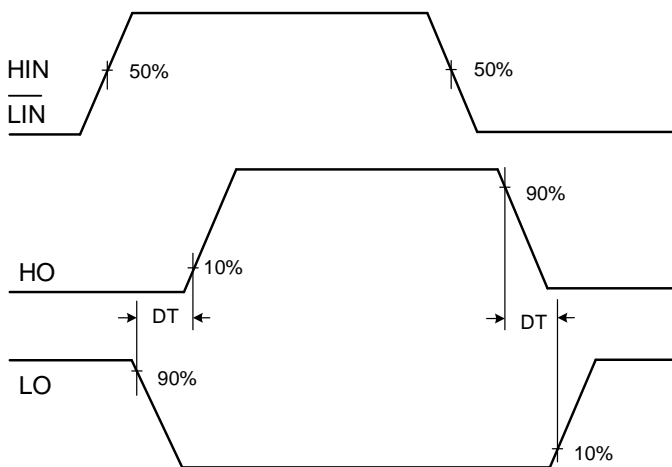

Figure 5. Dead Time Waveform

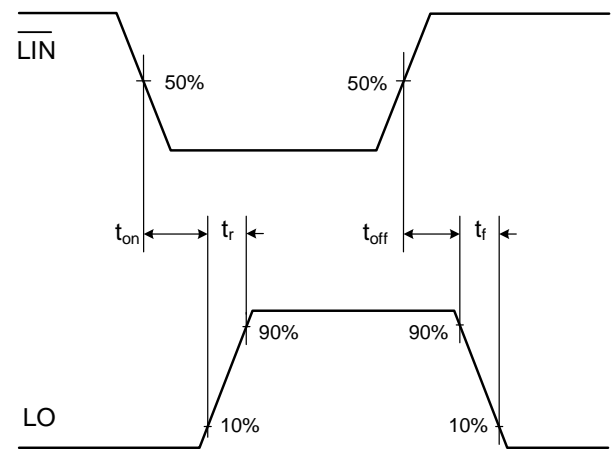

Figure 6. Low Side Switching Time Waveform

PACKAGE CASE OUTLINES

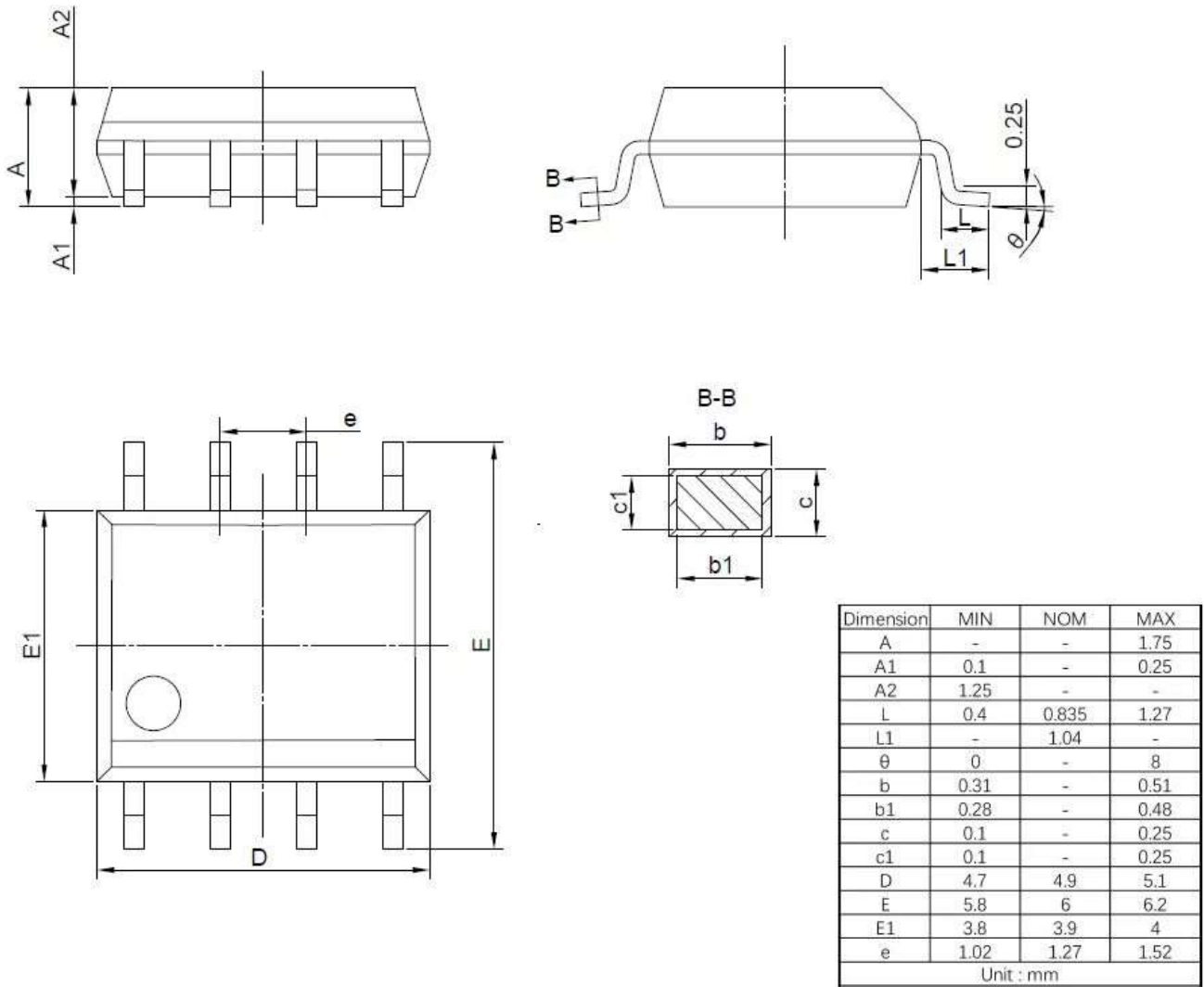

Figure 7. SOP8 Outline Dimensions

REVISION HISTORY

Note: page numbers for previous revisions may differ from page numbers in current version

Page or Item	Subjects (major changes since previous revision)
Rev 1.0 Datasheet, 2024-10-16	
Whole document	Initial released